

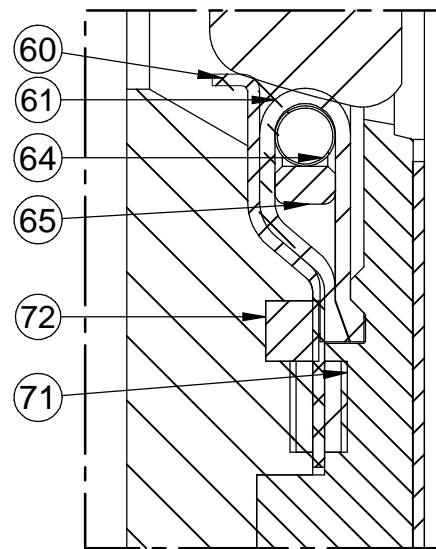

SECCION - SECTION A-A

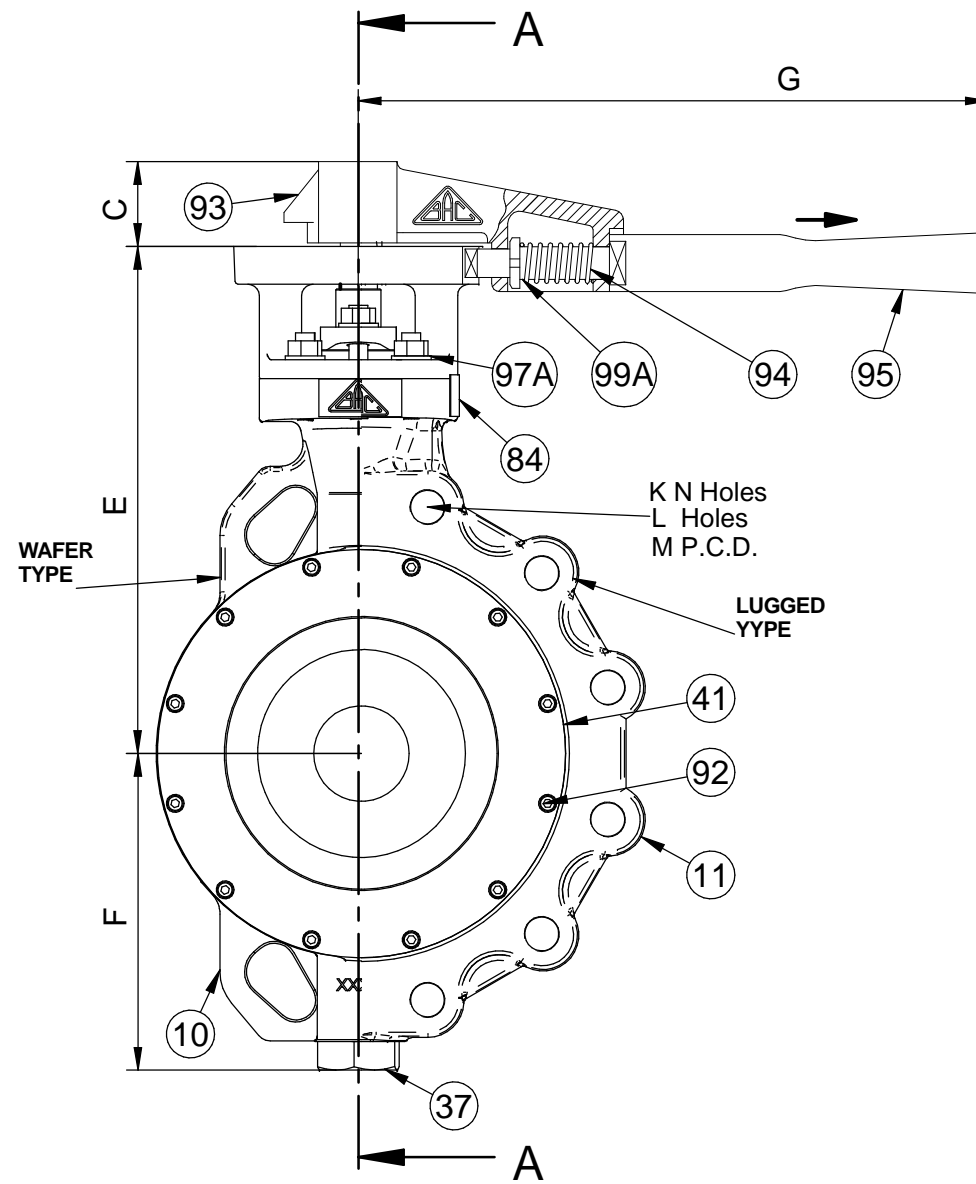

**DETALLE - DETAIL B
2:1**

- Design and dimensions are subject to change without notice, except the dimensions established by international standard
- Dimensions in mm

SIZE DN	80 3"	100 4"	125 5"	150 6"	200 8"	250 10"	300 12"	350 14"	400 16"	450 18"	500 20"	600 24"
D	74.6	86.7	120	144.1	193.8	235.8	286	310,8	367	414	466	563
A # 150	50	55.5	60	60	67	72	84	92	102	114	127	154
A # 300	50	55.5	60	60	76	86	94	117	133	149	159	181
B	134	157	186	218	271	324	381	432,8	490	546	597	712
C # 150	43	42,5	40	39,5	39	54	54,4	71	80	80	90	100
C # 300	43	42,5	40	39,5	54	54,4	71	74	76	89,5	100	110,3
E # 150	210	228	268	268	290	347	398	437	476	526	594	648
E # 300	210	228	268	268	317	402	426	507	573	605	640	692
F # 150	131	137	167,5	168	191	238	275	303	337	367	399	473
F # 300	131	137	167,5	168	205	263	295	336	373	405	437	492
G # 150	300		400		GEAR BOX							
G # 300	300		400		GEAR BOX							
K # 150	4	8		12			16		20			
K # 300	8		12		16			20		24		
L # 150	5/8"-11UNC		3/4"-10UNC		7/8"-9UNC			1"-8UNC		1 1/8"-8UNC		1 1/4"
L # 300	3/4"-10UNC		7/8"-9UNC		1"-8UNC		1 1/8"-8UNC		1 1/4"		1 1/2"	
M # 150	152	190.4	216	241.2	298.4	362	432	476,3	539,8	577,9	635	749,3
M # 300	168	200	235	270	330,2	387,4	451	514,4	571,5	628,6	685	812,8
WEIGHT (Kg)												
WAFER WR1 #150	11,8	14,3	18	26	33,7	53	80	114	160	210	234	410
WAFER WR3 #300	11,8	14,3	18	26	41,5	83	108	189	230	290	382	605
LUGGED LD1 #150	14,6	17,5	22,5	35	39	62,3	102	134	175	310	385	470
LUGGED LD3 #300	14,6	17,5	22,5	35	55,5	102	141	228	290	355	460	705

01	First Issue	J. Marchante	Jordi Font	11-06-2014
Rev.	Descripción / Description	Dibujado / Drawn	Aprobado / Approved	Fecha / Date
 BAC bac valves				
Tapis, 126 - P.O. Box, 13 - 17600 FIGUERES (Girona) Spain Tel.: (34) 972 67 70 52 - Fax: (34) 972 50 90 40 E-mail: technical@bacvalves.com web: www.bacvalves.com				
Título / Title PLANO GENERAL CON LISTA DE MATERIALES GENERAL DRAWING WITH MATERIAL LIST VÁLVULA DE MARIPOSA / BUTTERFLY VALVES TIPO / TYPE WAFER & LUGGED SOFT SEAT #150-300		Dibujado / Drawn J. Marchante		Escala / Scale
		Aprobado / Approved Jordi Font		Fecha / Date 11-06-2014
Plano nº / Drawing nr. DT-GAD-HPBFV-WR_LD-ANSI-SS-GRA-STD-H93				Rev. 01

99A	WRENCH STUD NUTS	1	CS SERIE KM ZINC PLATED		
99	GLAND STUD NUTS	6	ISO 3506 A2		
98	CUP-POINT-SETScrew	1	CS SERIE KM ZINC PLATED		
97A	STOOL STUD BOLTS	4	ISO 3506 A2-70		
97	GLAND STUD BOLTS	2	ISO 3506 A2-70		
96	WASHERS	6	ISO 3506 A2		
95	LEVER	1	NODULAR IRON GGG-41		
94	LEVER SPRING	1	SS302		
93	WRENCH SUPPORT	1	NODULAR IRON GGG-41		
92	SEAT RING CARRIER FASTENERS	-	ISO 3506 A4-70		
90	ACTUATOR KEY	1	ASTM A-564M 630		
89	GLAND FOLLOWER SLEEVE	2	PTFE VIRGIN		
81	GLAND PACKING	2	GRAPHITE		✓
85	PLUG THRUST WASHER	1	PTFE VIRGIN		
84	ID PLATE	1	ASTM A240 316		
80	PLUG GASKET	1	GRAPHITE		✓
72	SEAT GASKET	1	PTFE MOD.		✓
71	SEAT GASKETS	2	GRAPHITE		✓
65	SELF CENTERING SPRING	1	ASTM A479 316		✓
64	ELGILOY SPRING	1	ELGILOY		✓
61	PTFE SEAT	1	PTFE MOD.		✓
60	METAL SEAT	1	ASTM B446 N06625		
58	TOP BEARING RING	1	ASTM A479 316		
57	BOTTOM BEARING RING	1	ASTM A479 316		
56	FOLLOWER	1	ASTM A479 316		
55	GLAND PLATE	1	ASTM A351 CF8		
41	SEAT RING CARRIER	1	ASTM A351 CF8M	ASTM A216 WCC	
39	BOTTOM SHAFT BEARING	1	SS / PTFE / GRAPHITE / MP6		
38	TOP SHAFT BEARING	1	SS / PTFE / GRAPHITE / MP6		
37	PLUG	1	ASTM A479 316		
35	DISC KEY	1	ASTM A-564M 630		
30	SHAFT	1	ASTM A-564M 630		
20	DISC	1	ASTM A351 CF8M		
19	STOOL	1	ASTM A351 CF8	ASTM A216 WCC	
10-11	BODY	1	ASTM A351 CF8M	ASTM A216 WCC	
POS.	DENOMINATION	QTY.	MAT. SS VERSION	MAT. CS VERSION	SPARE PARTS

STANDARD**DESIGN****FACE TO FACE**

API 609

API 609 cat. B

FOR NPS 5", EN 558-1 serie 49

FLANGED

ASME B16,5 RF SMOOTH FINISH Ra 3.2-6.3 µm

INT.WETTED PARTS

NACE MR0175

TOP FLANGE

ISO 5211

PED

97/23/EC MODULE B+D

ANTI-STATIC

ISO 17292

FIRE-SAFE

ISO 10497, API 607 5ed.

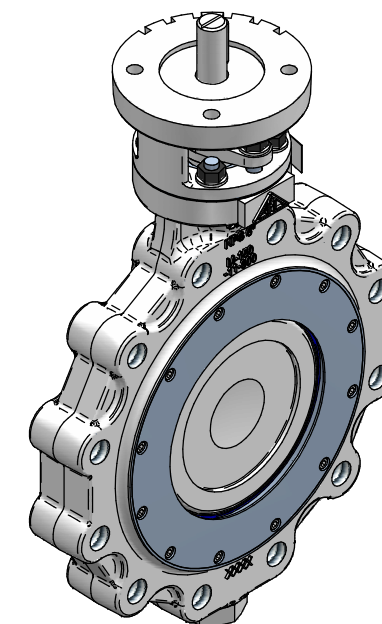

LUGGED TYPE

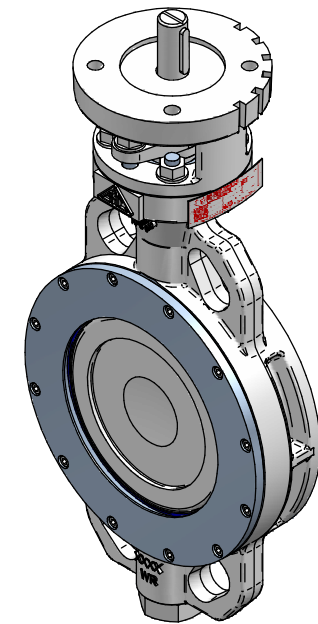

WAFER TYPE

01	First Issue	J. Marchante	Jordi Font	11-06-2014
Rev.	Descripción / Description	Dibujado / Drawn	Aprobado / Approved	Fecha / Date
 BAC bac valves				
Tapis, 126 - P.O. Box, 13 - 17600 FIGUERES (Girona) Spain Tel.: (34) 972 67 70 52 - Fax: (34) 972 50 90 40 E-mail: technical@bacvalves.com web: www.bacvalves.com				
Título / Title		Dibujado / Drawn	Escala / Scale	
PLANO GENERAL CON LISTA DE MATERIALES GENERAL DRAWING WITH MATERIAL LIST VÁLVULA DE MARIPOSA / BUTTERFLY VALVES TIPO / TYPE WAFER & LUGGED SOFT SEAT #150-300		J. Marchante	11-06-2014	
		Aprobado / Approved Jordi Font		
Plano nº / Drawing nr. DT-GAD-HPBFV-WR_LD-ANSI-SS-GRA-STD-H93		Rev.		01