



## Constant level control valve with on-off solenoid control Mod. XLC 365/465-MCP

The CSA Model XLC 365/465-MCP maintains the constant level of a tank, regardless of upstream pressure variations, by means of a flow modulating proportional pilot in stainless steel.

The circuit is also equipped with a solenoid to enable an on-off control mode in response to signals from remote or by a controller. Thanks to a CSA needle valve the response time can be adjusted, to prevent water hammer effects during the closing phase. Normally equipped with visual position indicator, and entirely made in ductile cast iron with FBT epoxy coating and stainless steel, the valve is designed to reduce head loss, throttling noise and cavitation damage.

### Applications

- For break pressure tanks with a proportional level control and emergency electronic backup, to prevent overflow.
- For level control on gravity fed pipelines with on/off mode operated from remote or alarms.

### Accessories

- On-off position transmitter Mod. CSA CSPO.
- Pressure measurement kit.
- Self-flushing and high capacity filter.
- AC anti-cavitation trim to provide a higher resistance to cavitation and accurate regulation in case of low flow.
- CSFL mechanical flow regulator.

### Note to the engineer

- Avoid bends and high points on the piping to connect the main valve with the level control pilot to prevent the formation of air pockets.
- For the proper functioning a minimum of 0,6 bar on the pilot is needed, failing in doing so would create delays and malfunctioning. Consider the use of a sustaining pilot for low pressure conditions and/or the CSA CSFL mechanical flow regulator.

### Additional features

- XLC 365/465-MCP-FR constant level valve with solenoid control and back-flow prevention.
- XLC 365/465-MCP-R constant level valve with solenoid control and surge prevention pilot.

### Working conditions

- Fluid: treated water.
- Minimum operating pressure: 0,6 bar on the pilot.
- Maximum operating pressure: 16 bar.
- Recommended working pressure: 6 bar. Higher on request.
- Maximum temperature: 70°C.

### Constant level pilot adjustment range

- 85 mm as a standard, different on request.

### Solenoid electrical data

- Voltages: 24 V DC, 24 V/50 Hz, 230 V/50 Hz. Other voltages on request.
- Power consumption: inrush AC (VA) 24, hold AC (VA) 17 (8 W), DC hot/cold coil 8/9 W.

## Operating principle

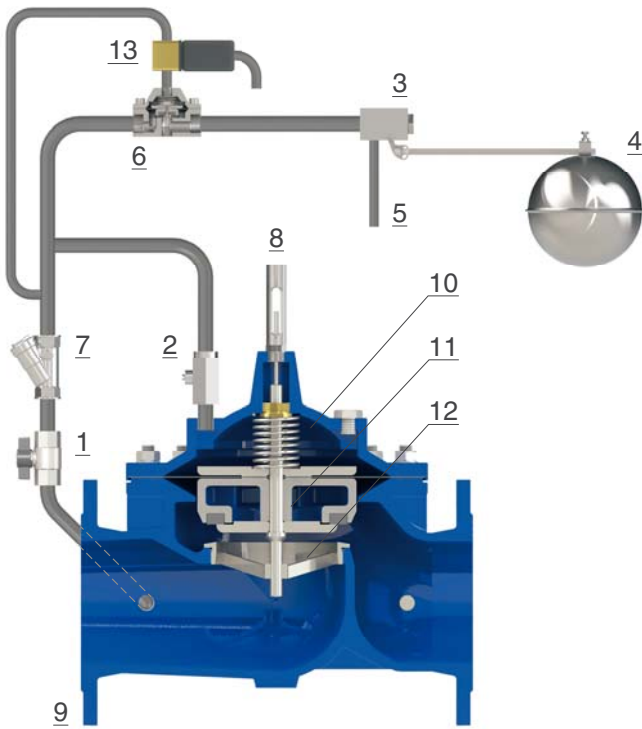

The XLC 365/465-MCP is operated by a 2 ways flow modulating proportional pilot (3) in stainless steel connected to the valve by means of a pipe, not supplied. Should the level inside the tank drop due to consumption the pilot (3) will open the drain (5) discharging the main chamber (10) to generate a passage through the seat (12), in proportion to the demand, lifting the obturator (11) upwards. Should the tank level rise due to the refilling the pilot (3) will modulate, throttling the flow through the drain (5) and, if required, closing the valve by putting the upstream pressure in communication with the chamber (10). In case of signals sent to the solenoid valve (13) the flow through the hydraulic accelerator (6) will be interrupted, therefore diverting the upstream pressure to the main chamber (10) and closing the main valve (9).

A fixed orifice is present on the filter (7) for the proper functioning, while a needle valve (2) on the chamber (10) will control pressure and flow in and out to prevent surges during closure.

## Installation layout

The XLC 365/465-MCP is linked to the pilot (2) through a single pipe and operated by signals sent by a CSA controller or from remote. Sectioning devices (1) are recommended for maintenance and a filter (3) is needed upstream, to prevent dirt from entering the main valve. The level pilot (2) should always be located in a position away from the turbulence created by the inlet supply pipe to the tank. In case of static values higher than 6 bar the AC (anti-cavitation) system and a CSA pressure reducer VRCD are advised.

